

# Measurement of the efficiency of a water spray system against diesel oil pool and spray fires

Magnus Arvidson  
Haukur Ingason

Measurement of the efficiency of  
a water spray system against  
diesel oil pool and spray fires

## Abstract

### Measurement of the efficiency of a water spray system against diesel oil pool and spray fires

Simple and robust test methodologies that make it possible to measure and quantify the effectiveness of water spray or water mist systems intended for 'large' shipboard machinery spaces were investigated. Heat Release Rate calorimetry is usually the best method to measure the effectiveness of a water spray or mist system, although not all fire laboratories have access to such equipment. Therefore, there is a need to explore if other traditional measurement techniques can be used. Such methods include thermocouples, heat flux gages and Plate Thermometers. An additional method, the Pipe Thermometer, has been developed and investigated within the project. It consists of an insulated thin-walled stainless steel tube having an outer diameter of 103 mm with numerous thermocouples welded on the outside surface.

The study, which was applied here on a water spray system, shows that the Pipe Thermometer is a possible method to use for evaluation of the efficiency of such system. It is definitely a better method than using heat flux meters or Plate Thermometer which were located at a distance from the fire source. The best correspondence between the measured data below the water spray system and the measured heat release rate was found between the measured gas temperature data and the measured convective heat release data. Consequently, there is no clear advantage of using the Pipe Thermometer (as mounted here) instead of traditional thermocouples at similar locations.

**Key words:** Shipboard machinery spaces, fire, fire protection, water spray, water mist, Heat Release Rate.

**SP Sveriges Provnings- och  
Forskningsinstitut**  
SP Rapport 2005:33  
ISBN 91-85303-64-X  
ISSN 0284-5172  
Borås 2005

**SP Swedish National Testing and  
Research Institute**  
SP Report 2005:33

Postal address:  
Box 857,  
SE-501 15 BORÅS, Sweden  
Telephone: +46 33 16 50 00  
Telex: 36252 Testing S  
Telefax: +46 33 13 55 02  
E-mail: info@sp.se

# Table of contents

	<b>Abstract</b>	
	<b>Förord</b>	
	<b>Sammanfattning</b>	
<b>1</b>	<b>Introduction</b>	<b>7</b>
<b>2</b>	<b>Measurement equipment and instrumentation</b>	<b>7</b>
2.1	The Pipe Thermometer	7
2.2	The Industry Calorimeter (Heat Release Rate Calorimetry)	9
2.3	System water pressure and water flow rate measurements	10
2.4	Heat flux measurements	10
<b>3</b>	<b>The system set-up</b>	<b>13</b>
3.1	System pipe-work	13
3.2	Water spray nozzle and system pressures	13
<b>4</b>	<b>Fire scenarios</b>	<b>14</b>
4.1	Diesel pool fires	14
4.2	Diesel spray fires	15
4.3	Fuel	16
<b>5</b>	<b>Test procedures</b>	<b>17</b>
5.1	Fire test procedures	17
5.2	Water discharge test procedures	17
<b>6</b>	<b>Test results and observations</b>	<b>18</b>
6.1	Pool fire tests	18
6.2	Spray fire tests	19
6.3	Water discharge tests	21
<b>7</b>	<b>Evaluation of the methodology</b>	<b>22</b>
7.1	Description of the analysing method	22
7.2	Pipe Thermometers	24
7.3	Gas temperatures	25
7.4	Heat radiation measurements	26
7.5	Plate Thermometers	28
<b>8</b>	<b>Discussion of the test results</b>	<b>29</b>
8.1	General	29
8.2	Diesel pool fire tests	29
8.3	Diesel spray fire tests	30
<b>9</b>	<b>Conclusions</b>	<b>32</b>
	<b>References</b>	

**Appendix A: Heat Release Rate measurement graphs**

**Appendix B: Selected photos from the tests**

## Preface

In 2001, the Swedish Government assigned VINNOVA, the Swedish Agency for Innovation Systems, the task of developing a special programme of development and research work in the field of maritime safety. In cooperation with the separate Programme Board for Shipping and Safety, which was set up, VINNOVA decided to provide support for 15 projects. One of the projects that received financing was focused on the use of water mist and water spray fire protection systems in machinery spaces onboard ships.

Two series of tests were conducted in the project; the first series of tests was inside a 500 m<sup>3</sup> test compartment [1] and the second series of tests was in a 250 m<sup>3</sup> test compartment [2] conducted between 2001 and 2003. The ceiling height was the same, 5,0 m, for both test compartments. The outcome of the project has been presented in detail previously [3, 4, 5] and will not be repeated here.

For Class 1 and Class 2 machinery spaces, i.e. spaces up to and including 3000 m<sup>3</sup>, a new fire test approach has been proposed, where the characteristics of the tested system are determined, in contrast to the simple measurements employed previously such as ‘time to extinguishment’. In addition, this new approach will allow scaling from the test compartment to smaller or larger compartments, given that the ceiling height and the water flux application rate of the system and the nozzle installation limitations are unchanged.

For the smaller Class 1 and Class 2 machinery spaces, it can be concluded that global oxygen depletion is the primary fire suppression and fire extinguishment mechanism. For the larger Class 3 machinery spaces, direct water spray impingement becomes an increasingly important mechanism. Due to this, another test approach is necessary.

Strengthened by the success of the previous project, The Swedish Mercantile Marine Foundation, VINNOVA, The Swedish Agency for Innovation Systems (project number 25744-1), and BRANDFORSK, The Swedish Fire Research Board (project number 400-041) decided to finance a project focused towards water spray and water mist protection of large shipboard machinery spaces. The internal SP project number was BRs 6099.

The ultimate goal of the project was to develop fire test procedures for water spray and water mist fire protection systems for ‘large’ shipboard machinery spaces, i.e., greater than 3000 m<sup>3</sup>.

## Sammanfattning

Projektets långsiktiga målsättning är att ta fram provningsmetoder och installationsanvisningar för vattenbaserade släcksystem i stora fartygsmaskinrum. I nuläget används oftast koldioxidssystem men koldioxidssystemens vara eller icke vara diskuteras mycket och många redare söker miljö- och personsäkra alternativ.

Statistik visar att en brand innebär höga skadekostnader. Ett vattenbaserat släcksystem har fördelen att det kan aktiveras i ett tidigt skede av brandförloppet och därmed minska skadorna.

Målsättningen med de försök som redovisas här har varit att utvärdera hur effektiviteten hos olika vattenspraysystem kan mätas. Därför genomfördes en serie försök där ett vattenspraysystem provades mot flera olika dieselpoolbränder respektive flera dieselspraybränder. Två vattenflöden användes. Antingen ett vattenflöde som motsvarade en vattentäthet om 5,0 mm/min eller 7,5 mm/min. Den förstnämnda vattentätheten stipuleras i kapitel 7 i den så kallade Fire Safety Systems koden (tidigare i SOLAS II-2, regel 10) för fartygsmaskinrum.

Under försöken mättes brandeffekten med hjälp av den så kallade Industrikalorimetern. Dessutom användes annan typ av mätutrustning, såsom mätning av gastemperaturen ovanför brandkällan, värmestrålningen och ett nyutvecklat mätinstrument, en s.k. "Pipe Thermometer".

Utvärderingen visar att mätning av gastemperatur bäst korrelerar mot den uppmätta brandeffekten.

Vad gäller systemens effektivitet kan man konstatera att det högre vattenflödet motsvarande 7,5 mm/min dämpar omedelbart poolbränderna ("fire suppression"), men släcker inte. Det lägre vattenflödet motsvarande 5,0 mm/min kontrollerar branden ("fire control").

Denna trend går igen i alla poolbrandförsök. En annan slutsats var att reduktionen av brandeffekten ökar med ökad diameter på baljan. Det kan tolkas så att inverkan av baljornas kanter fick mindre och mindre inverkan med ökande diameter.

En av spraybränderna släcktes, den minsta 1 MW branden vid 7,5 mm/min vattenflöde. För de högre brandeffekterna har inget av de två vattenflödena någon nämnvärd inverkan på branden, vilket kan sägas vara nästan typiskt för en spraybrand, antingen brinner de med full effekt eller så släcks de.

**Sökord:** Fartyg, fartygsmaskinrum, brand, brandskydd, vattendimma, sprinkler



# 1 Introduction

The objective of the project is to develop a simple and robust test methodology that makes it possible to measure and quantify the effectiveness of water spray or water mist systems used in spaces where the global oxygen depletion is not the primary fire suppression and fire extinguishment mechanism.

A methodology based on Heat Release Rate calorimetry in order to measure the effectiveness of a water spray or mist system is usually the best alternative. Not all fire laboratories have access to such equipment, however, so other alternatives are needed. Such alternatives can include: measurement of temperatures, heat radiation, or combinations of these parameters. In order to explore which alternatives could be feasible, a test program was undertaken to investigate the possibility of a methodology that is based on a simple and robust technology without using Heat Release Rate calorimetry. In the test program presented here, the Heat Release Rate Calorimetry will be used as a reference instrument in order to evaluate the methods investigated.

## 2 Measurement equipment and instrumentation

### 2.1 The Pipe Thermometer

The Plate Thermometer (PT) is a well-known instrument used for temperature control of furnaces for fire testing of building products or thermal measurements during fire tests. It was developed at SP and consists of a 100 mm by 100 mm, 0,7 mm thick plate, insulated on the backside by non-combustible material. The design of the Plate Thermometer is such that it primarily responds to heat radiation, and to a lesser degree, to convection, compared to a conventional wire thermocouple. A full description of the Plate Thermometer is given in references [6] and [7].

For the tests described in this report the Plate Thermometer was considered to be too frail, especially relative to direct exposure from a water spray. Therefore, the “Pipe Thermometer” was developed, based on the principles of the Plate Thermometer.

The Pipe Thermometer (PiP) is constructed from a thin-walled (1,5 mm) stainless steel tube having an outer diameter of 103 mm (inner diameter 100 mm). Thermocouples were welded on the outside surface every 1000 mm of the length of the tube. For each position, four thermocouples were used, one on each quadrant of the tube diameter.

In addition, one thermocouple was positioned 50 mm below the bottom part of the tube to record gas temperatures.

The tube was 6 m long and was filled with 50 L of Vermeculite insulation material. The outside surface was painted black using heat resistant paint.

All thermocouples mentioned above were of type K (chromel-alumel) and made from 0,5 mm wire welded together. Pentronic AB manufactures the wires. The quality is class 1, according to the IEC 584-1 standard, which means an accuracy of  $\pm 1,5^{\circ}\text{C}$  in the interval  $-40$  to  $+375^{\circ}\text{C}$  and 0,04% of measured value above  $375^{\circ}\text{C}$ .

Figures 1 and 2 show the design of the Pipe Thermometer and the position of the thermocouples.

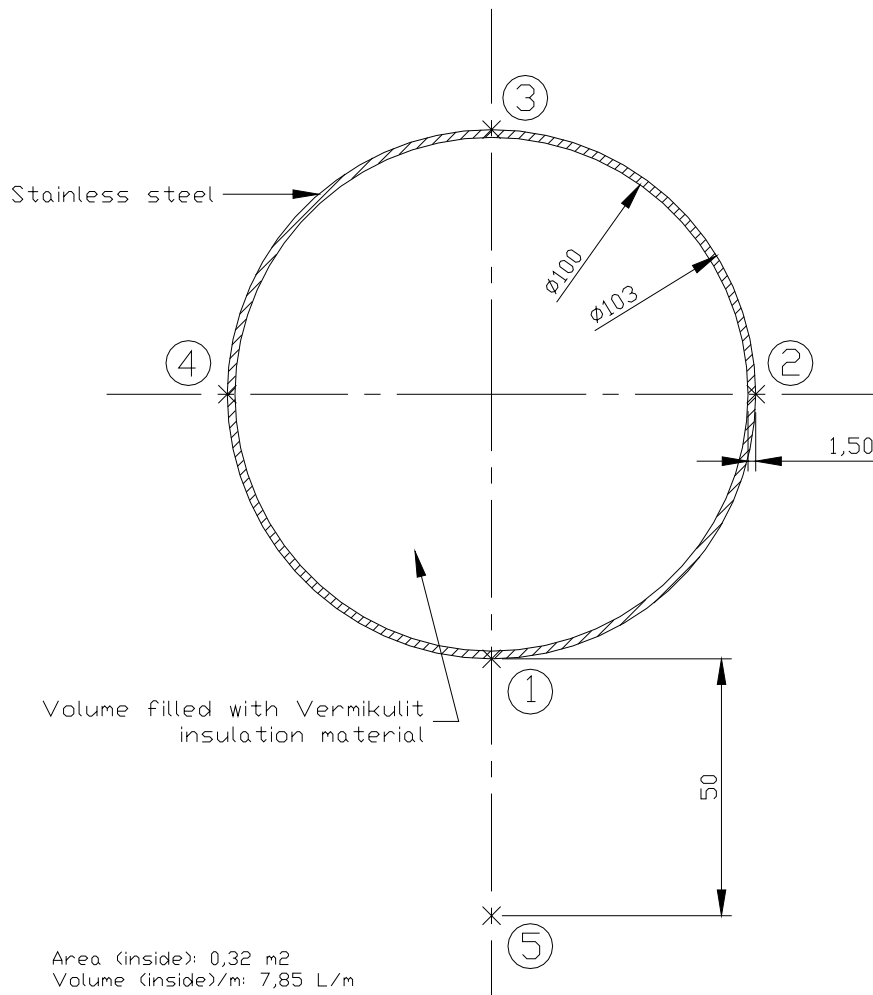

Figure 1 The Pipe Thermometer with the position of the thermocouples on the perimeter of the pipe.

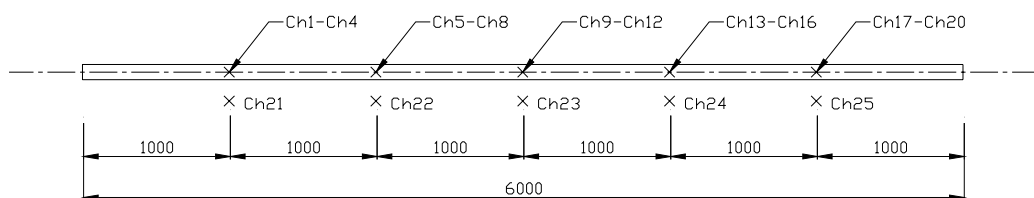

Figure 2 The position of the thermocouples along the length of the Pipe Thermometer.

For the pool fire tests, the lower Pipe Thermometer was placed at a fixed vertical distance of 950 mm between the surface of the fuel and the centreline of the pipe, for tests 1.1 to 1.8. From test 1.9 the pipe was lowered such that the centreline was 650 mm above the fuel surface.

For the spray fire tests, the lower Pipe Thermometer was placed with its centreline 100 mm above the steel grating used for these particular tests. The vertical distance measured from the fuel spray nozzle to the centreline of this Pipe Thermometer measured 1,6 m.

The upper Pipe Thermometer was positioned at a fixed distance, i.e. the centreline was 4,0 m above the floor for all the tests. This equalled a vertical distance of 500 mm measured from the centreline of the Pipe Thermometer to the centreline of the system pipe-work.

## 2.2 The Industry Calorimeter (Heat Release Rate Calorimetry)

The tests were conducted under the Industry Calorimeter, a large hood connected to an evacuation system capable of collecting all the combustion gases produced by the fire. The hood is 6 m in diameter with its lower rim 7,2 m above the floor. To increase the gas collecting capacity of the hood, a cylindrical fibreglass "skirt", hanging from the lower rim of the hood, was used. The height of the fibreglass "skirt" was 2,5 m. In the duct to the evacuation system, measurements of gas temperature, velocity and the generation of gaseous species such as CO<sub>2</sub> and CO and depletion of O<sub>2</sub> were made. Based on these measurements both the convective and the total heat release rate were calculated.



*Figure 3 The Industry Calorimeter was used to measure the Heat Release Rates from the fires. The system pipe-work and the uppermost Pipe Thermometer can be seen below the calorimeter.*

The convective heat release rate is denoted  $HRR_{conv}$  and can be defined as follows:

**HRR<sub>conv</sub>:** The convective part of the heat release rate measured during a test, calculated on the basis of the gas temperature and mass flow rate in the calorimeter system.

The total heat release rate is denoted  $HRR_{tot}$  and can be defined as follows:

**$HRR_{tot}$ :** The total heat release rate measured during a test, calculated on the basis of oxygen depletion in the calorimeter system.  $HRR_{tot}$  is comprised of both the convective and radiative heat release.

### 2.3 System water pressure and water flow rate measurements

The system water pressures was measured at two positions, at the pump, or, for the water spray system tests, at the public water supply and at the pipe-work grid, using Transinstrument 2000A pressure transducers.

The total water flow rate was measured using a Krohne 0 – 2000 L/min flow meter.

### 2.4 Heat flux measurements

The heat flux from the fire was recorded with Schmidt Boelter total heat flux meters manufactured by Medtherm Co (water cooled system). The instruments have a measurement range of 0 - 10 kW/m<sup>2</sup>. Two heat flux meters were used, positioned 2,0 m and 4,0 m, respectively, from the fire, 1,0 m above the floor.

In addition, a Plate Thermometer was positioned at the same horizontal distance from the fire source and vertical distance above the floor as the heat flux meters, respectively. For the measurement position closest to the fire a horizontal steel plate was used to prevent water from reaching the measurement equipment.



Figure 4 One of the heat flux meters and the adjacent Plate Thermometer.

*Table 1 Measurement positions and associated channels.*

Channel No.	Description and position
	<u>Pipe thermometer close to the water spray system</u>
Ch 21	Welded to the surface, +1000 mm, position 1
Ch 22	Welded to the surface, +1000 mm, position 2
Ch 23	Welded to the surface, +1000 mm, position 3
Ch 24	Welded to the surface, +1000 mm, position 4
Ch 25	Welded to the surface, +2000 mm, position 1
Ch 26	Welded to the surface, +2000 mm, position 2
Ch 27	Welded to the surface, +2000 mm, position 3
Ch 28	Welded to the surface, +2000 mm, position 4
Ch 29	Welded to the surface, +3000 mm (mid-point), position 1
Ch 30	Welded to the surface, +3000 mm (midpoint), position 2
Ch 31	Welded to the surface, +3000 mm (mid-point), position 3
Ch 32	Welded to the surface, +3000 mm (mid-point), position 4
Ch 33	Welded to the surface, +4000 mm, position 1
Ch 34	Welded to the surface, +4000 mm, position 2
Ch 35	Welded to the surface, +4000 mm, position 3
Ch 36	Welded to the surface, +4000 mm, position 4
Ch 37	Welded to the surface, +5000 mm, position 1
Ch 38*	Welded to the surface, +5000 mm, position 2
Ch 39	Welded to the surface, +5000 mm, position 3
Ch 40	Welded to the surface, +5000 mm, position 4
Ch 61	Gas temperature, +1000 mm, 50 mm below the pipe, position 5
Ch 62	Gas temperature, +2000 mm, 50 mm below the pipe, position 5
Ch 63	Gas temperature, +3000 mm, 50 mm below the pipe, position 5
Ch 64	Gas temperature, +4000 mm, 50 mm below the pipe, position 5
Ch 65	Gas temperature, +5000 mm, 50 mm below the pipe, position 5
	<u>Pipe thermometer close to the fire</u>
Ch 41	Welded to the surface, +1000 mm, position 1
Ch 42	Welded to the surface, +1000 mm, position 2
Ch 43	Welded to the surface, +1000 mm, position 3
Ch 44	Welded to the surface, +1000 mm, position 4
Ch 45	Welded to the surface, +2000 mm, position 1
Ch 46	Welded to the surface, +2000 mm, position 2
Ch 47	Welded to the surface, +2000 mm, position 3
Ch 48	Welded to the surface, +2000 mm, position 4
Ch 49	Welded to the surface, +3000 mm (mid-point), position 1
Ch 50	Welded to the surface, +3000 mm (midpoint), position 2
Ch 51	Welded to the surface, +3000 mm (mid-point), position 3
Ch 52	Welded to the surface, +3000 mm (mid-point), position 4
Ch 53	Welded to the surface, +4000 mm, position 1
Ch 54	Welded to the surface, +4000 mm, position 2
Ch 55	Welded to the surface, +4000 mm, position 3
Ch 56	Welded to the surface, +4000 mm, position 4
Ch 57	Welded to the surface, +5000 mm, position 1
Ch 58	Welded to the surface, +5000 mm, position 2
Ch 59	Welded to the surface, +5000 mm, position 3
Ch 60	Welded to the surface, +5000 mm, position 4
Ch 81	Gas temperature, +1000 mm, 50 mm below the pipe, position 5
Ch 82	Gas temperature, +2000 mm, 50 mm below the pipe, position 5
Ch 82	Gas temperature, +3000 mm, 50 mm below the pipe, position 5
Ch 84	Gas temperature, +4000 mm, 50 mm below the pipe, position 5
Ch 85	Gas temperature, +5000 mm, 50 mm below the pipe, position 5

---

Ch 91	Plate Thermometer, positioned 2,0 m from the fire
Ch 92	Plate Thermometer, positioned 4,0 m from the fire
Ch 93	Heat flux meter, positioned 2,0 m from the fire
Ch 94	Heat flux meter, positioned 4,0 m from the fire
Ch 95	System water flow rate
Ch 98	Water pressure (at the water supply)
Ch 99**	Water pressure (system pressure)

---

\*) Out of function prior to the tests.

\*\*\*) Used only during the water discharge tests.

## **3 The system set-up**

### **3.1 System pipe-work**

A piping arrangement was fabricated consisting of a single feed piping grid system, which was installed to minimise the difference between the flow rates of the nozzles. Two 32 mm cross connections spaced 3,0 m apart were made between the 40 mm mains to serve as the feed lines to the individual nozzles under the test. At 3,0 m spacing along the cross connections, 15 mm diameter pipe drops were installed down to the pendent nozzles. The system was fitted with a pressure transducer so that the operator could adjust the pump output and maintain the specific flowing pressure in response to any pressure changes.

### **3.2 Water spray nozzle and system pressures**

The nozzle used in the tests was made by Tyco Fire Products and designated Protectospray D3 18-95. The nozzle type had a K-factor of 25,9 (metric) and a spray angle of 95°.

A nominal flowing pressure of either 3,0 bar or 6,8 bar was utilised throughout the tests, which provided for a flow rate per nozzle of 45 L/min and 67,5 L/min, respectively. The total flow rate for the four nozzles was 180 L/min or 270 L/min and the corresponding nominal discharge density 5,0 mm/min and 7,5 mm/min, respectively.

The water was taken directly from the public water main and was increased to the desired pressure using a pump unit.

This water discharge density of 5,0 mm/min corresponds to the requirements of Chapter 7 of the FSS Code [8]. Previously these requirements were found in SOLAS II-2, regulation 10.

## 4 Fire scenarios

### 4.1 Diesel pool fires

The pool fires had nominal heat release rates ranging from 1 MW to 6 MW and were fully exposed to the water spray from the nozzles.

The pool fires were arranged in circular trays with diameters chosen to provide the desired heat release rate. The rim height of the trays was either 200 mm or 300 mm and the trays were filled with 50 mm of fuel, without any water bed. For the larger trays, the bottom of the tray was positioned 100 mm above the floor (as the bottom area required reinforcement and holes for the fork lift to allow the trays to be lifted). Table 2 provides information on the trays and Table 3 the theoretical flame heights.

*Table 2 The sizes of the pool fire trays.*

Nominal HRR	Diameter [mm]	Area [m <sup>2</sup> ]	Rim height [mm]	Amount of fuel [L]	Free-board [mm]	Distance from the bottom of the tray to the floor [mm]
1 MW	1100	0,95	200	47,5	150	0
2 MW	1440	1,63	300	81,5	250	0
3,5 MW	1890	2,80	200	140	150	100
6 MW	2400	4,52	200	226	150	100

*Table 3 Theoretical flame heights for the pool fires.*

Nominal HRR	Diameter [mm]	Area [m <sup>2</sup> ]	Flame height, L <sub>f</sub> [m]
1 MW	1100	0,95	2,60
2 MW	1440	1,63	3,45
3,5 MW	1890	2,80	4,11
6 MW	2400	4,52	5,18

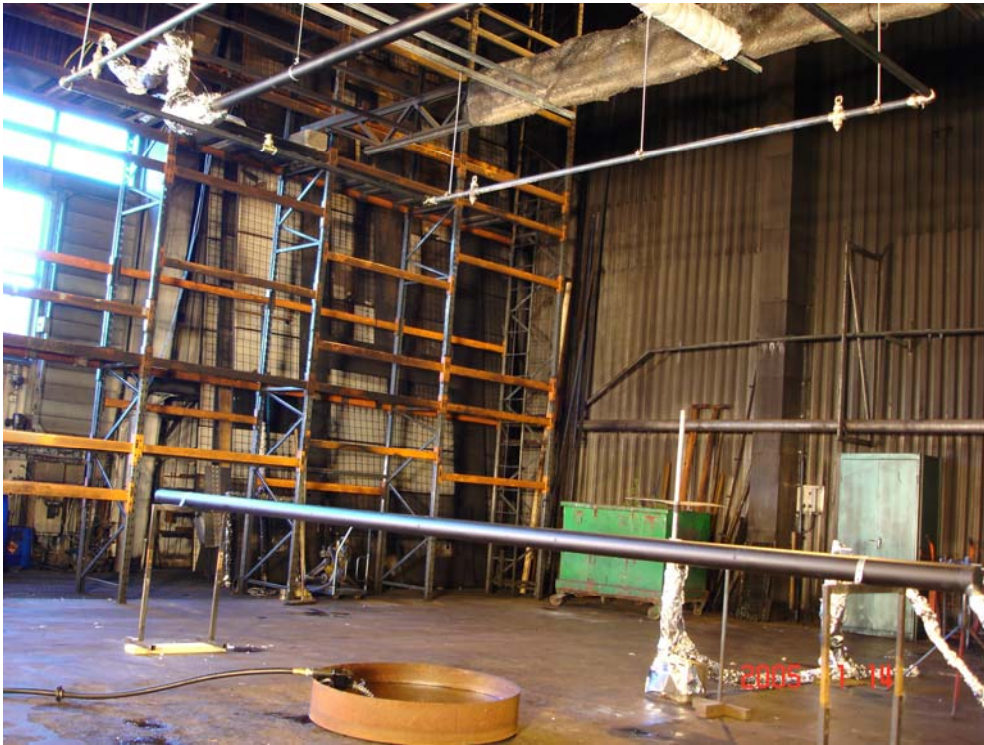

Figure 5 The smallest of the fire trays. Note the Pipe Thermometer directly above the fire tray and the Pipe Thermometer above the water spray system grid.

## 4.2 Diesel spray fires

The fuel spray nozzle was directed vertically upward and positioned 1,0 m above the floor. The fuel spray hit a re-ignition source consisted of a horizontal steel grating, having a mesh size of 33 mm by 37 mm. The steel grating was constructed from steel strips each with a cross-section of 30 mm × 3 mm at an individual distance of 33 mm and 6 mm crossbars at an individual distance of 37 mm.

The horizontal wire mesh had an overall area of 2,0 m by 2,0 m and was positioned 2,0 m above floor level.

The fuel spray nozzles were directed vertically upward and were positioned 0,5 m above the floor. A small steel bar (dia=5 mm, length=150 mm) was positioned 400 mm above the fuel spray nozzle. This steel bar acted as a re-ignition source and flame stabiliser.

For the calculation of the fuel flow, a net heat of combustion of 43,2 MJ/kg and an assumed burning efficiency of 0,91, was used<sup>1</sup>.

Table 4 The fuel pressure, fuel flow rate and the associated fuel nozzle.

Nominal HRR	Fuel pressure [bar]	Fuel flow rate [kg/s]	Fuel flow rate [kg/min]	Nozzle type
1 MW	8 bar	0,0254	1,52	460.404
2 MW	13 bar	0,051	3,05	460.484
3,5 MW	10 bar	0,089	5,34	460.608

<sup>1</sup> The tests indicated that the burning efficiency was higher, probably close to 1,0.

All the fuel spray nozzles used in the tests were manufactured by Lechler GmbH in Germany.



*Figure 6 The oil spray nozzle was positioned 500 mm above floor and directed vertically upward towards a steel grating.*

### **4.3 Fuel**

Shell CityDiesel® was used as the fuel. The fuel had the following properties (test procedure within parenthesis):

Density at 15°C: 817 kg/m<sup>3</sup> (SS-EN-ISO 3675)  
Viscosity at 40°C: 2,0 mm<sup>2</sup>/s (CsT) (SS-ISO 3104)  
Flash point: 74°C (SS-ISO 2719)  
Water content: 34 mg/kg (ASTM D 1744)  
Heat of combustion: 43,2 MJ/kg (ASTM D 2624)

The fuel temperature measured prior to the tests was approximately 8°C.

## **5 Test procedures**

### **5.1 Fire test procedures**

The fires were ignited using a torch, and allowed to burn for 2 minutes before the water flow was initiated. For the diesel pool fires, a small amount (500 mL) of n-Heptane was used to obtain ignition.

The fire test procedure was as follows:

- 02:00 Start of the measurement
- 00:00 Ignition of the fire
- 02:00 Initiation of the water
- 12:00 Manual extinguishment using a foam nozzle (the pool fire tests) or by turning off the fuel pump unit (the spray fire tests).
- 13:00 Termination of the test

The level of fuel in the tray was observed after the end of the applicable tests to make sure that no limitation of fuel occurred during the test.

### **5.2 Water discharge test procedures**

The water discharge densities of the two systems were measured between the four nozzles using 25 pcs of water collector trays under non-fire conditions. Each tray measured 500 mm by 500 mm. Each discharge test was conducted for two minutes and the amount of water in each tray was determined by weighing the water.

The lower Pipe Thermometer was not used in the water discharge tests.

## 6 Test results and observations

This section provides a summary of the test results and observations. Heat Release Rate measurement graphs are provided in Appendix A.

### 6.1 Pool fire tests

The table below shows the nominal Heat Release Rates of the pool fire trays versus the actual total and convective Heat Release Rates that were measured with the Industry calorimeter. For the estimation of the theoretical Heat Release Rates a burning efficiency of 0,91 was assumed. The desired value was determined from tests performed in other pool sizes. The given values were calculated as the X-minute (X is given below), calculated from two minutes after the ignition of the fuel. It can be concluded that the nominal values correspond reasonably well with the measured values, except for the 1 MW pool fire that measured higher than desired.

Table 5 The nominal Heat Release Rates versus the actual, measured values.

Nominal HRR [MW]	Actual HRR <sub>tot</sub> [kW]	Actual HRR <sub>conv</sub> [kW]	X [minutes]
1 MW	1150	715	10
2 MW	2060	1220	10
3,5 MW	3540	2175	8
6 MW	5140*	3140*	2

\*) Combustion gases escaped the Industry Calorimeter, thereby reducing the measured HRR.

All times to extinguishment given in the tables below are calculated from the ignition of the fire, not from the activation of the system, in order to provide comparable data irrespective of the pre-burn time.

Table 6 Summary of fire test results (pool fire tests).

	Test1.2FB(1)P	Test1.3FB(1)P	Test1.4WS(1)P	Test1.5WS(1)P
Date of test	Jan 17, 2005	Jan 17, 2005	Jan 17, 2005	Jan 17, 2005
Fire scenario	Pool fire	Pool fire	Pool fire	Pool fire
Nominal HRR	1 MW	1 MW	1 MW	1 MW
Nozzle identification	Free-burn	Free-burn	Protectospray	Protectospray
Water flow rate (L/min)	--	--	180	270
Nominal density (mm/min)	--	--	5,0	7,5
Notes:	1	--	--	--

1) No temperature measurements conducted.

Table 7 Summary of fire test results (pool fire tests).

	Test1.6WS(2)P	Test1.7WS(2)P	Test1.8FB(2)P
Date of test	Jan 17, 2005	Jan 17, 2005	Jan 17, 2005
Fire scenario	Pool fire	Pool fire	Pool fire
Nominal HRR	2 MW	2 MW	2 MW
Nozzle identification	Protectospray	Protectospray	Free-burn
Water flow rate (L/min)	270	180	--
Nominal density (mm/min)	7,5	5,0	--
Notes:	--	1	2

1) Tempered water-cooling of the heat flux meters from this test.

2) Non-uniform heating of the lowest Pipe Thermometer as the flame tilted.

Table 8 Summary of fire test results (pool fire tests).

	Test1.9WS(3.5)P	Test1.10WS(3.5)P	Test1.11FB(3.5)P
Date of test	Jan 18, 2005	Jan 18, 2005	Jan 18, 2005
Fire scenario	Pool fire	Pool fire	Pool fire
Nominal HRR	3,5 MW	3,5 MW	3,5 MW
Nozzle identification	Protectospray	Protectospray	Free-burn
Water flow rate (L/min)	270	180	--
Nominal density (mm/min)	7,5	5,0	--
Notes:	1, 2, 3	1	1

- 1) The bottom of the tray was positioned 100 mm above floor level.
- 2) The lowest positioned Pipe Thermometer was lowered to 650 mm above the fuel surface from this test.
- 3) The welded thermocouple at Ch49 was broke after the pre-burn time. Repaired for tests 1.10 and 1.11.

Table 9 Summary of fire test results (pool fire tests).

	Test1.12WS(6)P	Test1.13WS(6)P	Test1.14FB(6)P
Date of test	Jan 18, 2005	Jan 18, 2005	Jan 18, 2005
Fire scenario	Pool fire	Pool fire	Pool fire
Nominal HRR	6 MW	6 MW	6 MW
Nozzle identification	Protectospray	Protectospray	Free-burn
Water flow rate (L/min)	270	180	--
Nominal density (mm/min)	7,5	5,0	--
Notes:	1	2	3

- 1) A certain degree of smoke escaped the hood of the Industry Calorimeter during the free-burn phase (Tests 1.12 and 1.13) and for the entire test 1.14.
- 2) The welded thermocouple at Ch49 was broken from the start of the test and not repaired for the rest of the test series.
- 3) The fire was only burnt for 04:00 [min:sec] from ignition before manually extinguished to limit the impact on the measurement equipment.

## 6.2 Spray fire tests

The table below shows the nominal Heat Release Rates of the spray fires versus the measured total and convective Heat Release Rates that were obtained with the Industry calorimeter. The given values were calculated as the X-minute (X is given below), calculated from two minutes after the ignition of the fuel. It can be concluded that the nominal values were consistently lower than the measured values. The reason is that the burning efficiency of the spray fires was higher than expected. For the calculation of the nominal Heat Release Rates a burning efficiency of 0,91 was assumed, although, the burning efficiency was probably closer to 1,00.

Table 10 The nominal Heat Release Rates versus the actual, measured values.

Nominal HRR [MW]	Measured HRR <sub>tot</sub> [kW]	Measured HRR <sub>conv</sub> [kW]	X [minutes]
1 MW	1070	670	10
2 MW	2290	1425	10
3,5 MW	3780	2310	10

Table 11 Summary of fire test results (spray fire tests).

	Test2.1WS(1)S	Test2.2WS(1)S	Test2.3WS(1)S	Test2.4FB(1)S
Date of test	Jan 19, 2005	Jan 19, 2005	Jan 19, 2005	Jan 19, 2005
Fire scenario	Spray fire	Spray fire	Spray fire	Spray fire
Nominal HRR	1 MW	1 MW	1 MW	1 MW
Nozzle identification	Protectospray	Protectospray	Protectospray	Free-burn
Water flow rate (L/min)	270	270	180	--
Nominal density (mm/min)	7,5	7,5	5,0	--
Notes:	1	2, 3	--	--

- 1) The fire did not burn properly prior to the start of the system.
- 2) A re-ignition steel bar (dia=5 mm) was positioned 400 mm above the fuel spray nozzle from this test.
- 3) The fire was extinguished 03:20 [min:sec] after ignition.

Table 12 Summary of fire test results (spray fire tests).

	Test2.5WS(2)S	Test2.6WS(2)S	Test2.7FB (2)S
Date of test	Jan 19, 2005	Jan 19, 2005	Jan 19, 2005
Fire scenario	Spray fire	Spray fire	Spray fire
Nominal HRR	2 MW	2 MW	2 MW
Nozzle identification	Protectospray	Protectospray	Free-burn
Water flow rate (L/min)	270	180	--
Nominal density (mm/min)	7,5	5,0	--
Notes:	1	--	2

- 1) The lower part of the flame (below the steel grating) was extinguished after 11:25 [min:sec].
- 2) The measurement duration time was prolonged to 44:00 [min:sec] to provide Pipe Thermometer cooling down data.

Table 13 Summary of fire test results (spray fire tests).

	Test2.8WS(3.5)S	Test2.9WS(3.5)S	Test2.10FB(3.5)S
Date of test	Jan 19, 2005	Jan 20, 2005	Jan 20, 2005
Fire scenario	Spray fire	Spray fire	Spray fire
Nominal HRR	3,5 MW	3,5 MW	3,5 MW
Nozzle identification	Protectospray	Protectospray	Free-burn
Water flow rate (L/min)	270	180	--
Nominal density (mm/min)	7,5	5,0	--
Notes:	--	--	--

### 6.3 Water discharge tests

The tables below present the results from the water discharge density measurements. Each discharge test was conducted for two minutes and the amount of water in each tray was determined by weighing the water. The tables provide the results in mm/min (equal to L/m<sup>2</sup>/min).

*Table 14 Measured water discharge densities for the system having a nominal density 5 mm/min.*

<b>7,08</b>	<b>4,20</b>	<b>5,04</b>	<b>5,00</b>	<b>5,48</b>
21	22	23	24	25
<b>4,68</b>	<b>4,28</b>	<b>4,48</b>	<b>4,56</b>	<b>3,44</b>
16	17	18	19	20
<b>4,16</b>	<b>3,88</b>	<b>3,08</b>	<b>3,72</b>	<b>4,60</b>
11	12	13	14	15
<b>4,00</b>	<b>5,64</b>	<b>3,88</b>	<b>4,88</b>	<b>5,04</b>
6	7	8	9	10
<b>5,20</b>	<b>5,44</b>	<b>6,00</b>	<b>5,08</b>	<b>5,40</b>
1	2	3	4	5

It can be concluded that the water discharge density for the water spray system was relatively uniform between the four nozzles, with higher densities measured in the corner trays, i.e. the trays close to the nozzles. The average discharge density measured 4,72 mm/min compared to the nominal discharge density of 5,0 mm/min.

*Table 15 Measured water discharge densities for the system having a nominal density 7,5 mm/min.*

<b>9,58</b>	<b>5,92</b>	<b>5,41</b>	<b>6,62</b>	<b>8,45</b>
21	22	23	24	25
<b>8,74</b>	<b>5,07</b>	<b>5,30</b>	<b>6,04</b>	<b>6,48</b>
16	17	18	19	20
<b>4,34</b>	<b>4,29</b>	<b>5,19</b>	<b>5,26</b>	<b>5,16</b>
11	12	13	14	15
<b>7,91</b>	<b>6,32</b>	<b>5,06</b>	<b>5,30</b>	<b>7,37</b>
6	7	8	9	10
<b>13,82</b>	<b>8,63</b>	<b>6,03</b>	<b>5,25</b>	<b>8,17</b>
1	2	3	4	5

It can be concluded that the water discharge density for the water spray system was relatively uniform between the four nozzles, with higher densities measured in the corner trays, i.e. the trays close to the nozzles. The average discharge density measured 6,63 mm/min compared to the nominal discharge density of 7,5 mm/min.

## 7 Evaluation of the methodology

In order to measure the efficiency of the water spray system and to evaluate the proposed methodology, an analysis of the measurement data is presented. The analysis include measured data from the Industry Calorimeter, the surface temperature of the Pipe Thermometer, the gas temperatures measured 50 mm below the lower edge of the Pipe Thermometer, the heat flux gauges and the Plate Thermometers were placed at 2 m and 4 m from the fire source, respectively.

The surface temperature of the Pipe Thermometer was expected to be an indicator of the heat exposure towards the surface and therefore it was assumed that a correlation between the total heat release rates (and/or the convective heat release rate) and the measured surface temperatures of the Pipe Thermometer would exist. Similar correlations were expected for the other instruments used in the study.

A way to evaluate the efficiency of the water spray system is to compare the data from the free-burning tests to the data from the corresponding fire suppression test. Consequently, the following hypotheses were tested:

- Does the relative reduction, compared to corresponding free-burning test, in the average surface temperature of the Pipe Thermometer correlate to the corresponding relative reduction in the average heat release rate and/or the convective heat release rate?
- Does the relative reduction, compared to corresponding free-burning test, in the average gas temperature measured below the Pipe Thermometers correlate to the corresponding relative reduction in the average heat release rate and/or the convective heat release rate?
- Does the relative reduction, compared to corresponding free-burning test, in the heat flux measurements at 2 m and/or 4 m from the fire source correlate to the corresponding relative reduction in the average heat release rate?
- Does the relative reduction, compared to corresponding free-burning test, in the Plate Thermometer measurements at 2 m and/or 4 m from the fire source correlate to the corresponding relative reduction in the average heat release rate?

### 7.1 Description of the analysing method

For the analysis of the data, the arithmetic average values, both in time and space, were used. The time average was taken from 2 minutes into the test (start of water spray system) until 12 minutes into the test.

The way the average of the measured data was taken depends on the number of measurement points. For example, the surface temperature of the Pipe Thermometer included 20 measurement points; four points at the perimeter (see Figure 1) at five positions along its length (see Figure 2). The gas temperature was measured 50 mm below the lower edge of each Pipe Thermometer, at the same five positions along the length of the Pipe (see Figures 1 and 2).

First, the average of the surface temperatures at the four points on the perimeter, were taken. The heat exposure to each of these points, as well as the possibility for water droplets to hit the surface can vary along the perimeter but for the purpose of this study it is acceptable to use the average temperature of all four points. It is more difficult to determine how many of the points along the axis of the Pipe Thermometer should be included. The Pipe Thermometer was mounted at two elevations, close to the fire (CTF) and close to the water spray system (WSS), respectively.

Therefore, the radial and vertical distribution of the plume gas temperature, and thereby the heat exposure to each measurement point, varies depending on the elevation.

In Figure 7, the average gas temperature (GT), 50 mm underneath the Pipe Thermometer, and surface temperatures (PT) close to the water spray system using 1 point, 3 points or 5 points for Test 1.3 (free-burning pool fire test), are shown. The position of the single point was +3 m (see Figure 2), the positions of the 3 points was +2 m, +3 m and +4 m, respectively, and the position of the 5 points was +1 m to +5 m with an interval of 1 m. The total length of the Pipe Thermometer was 6 m. The highest values were obtained with only 1 point (at the centre), followed by 3 points and the lowest values with 5 points, as would be expected.

This can be easily explained by the radial distribution of the plume temperature, where the highest temperatures are obtained close to the centre and lowest temperatures close to the edge of the Pipe Thermometer. Therefore, the average temperature decreases with the number of measurement points included.

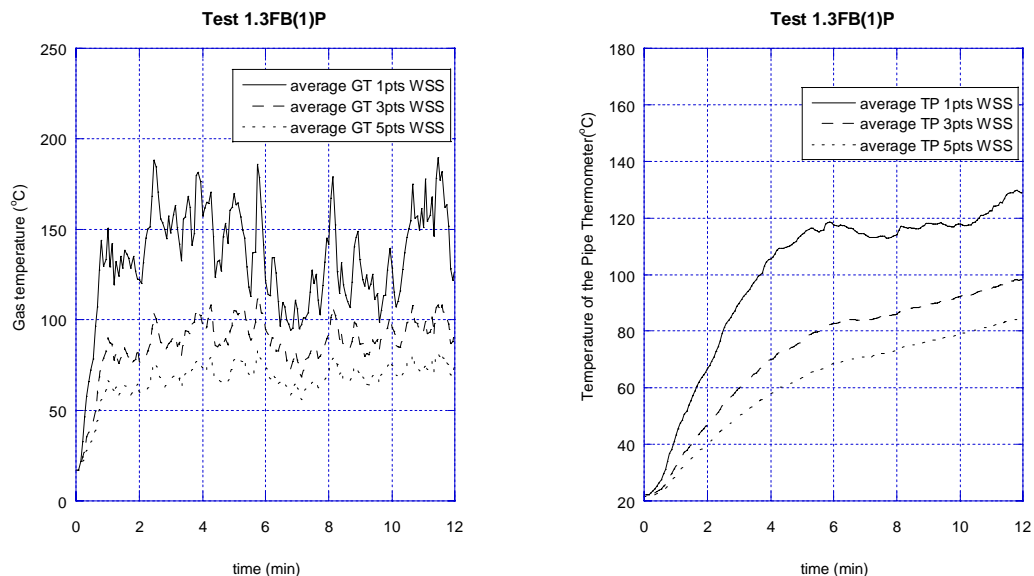

Figure 7 Comparison of using different number of measurement points (pts) for gas temperature (left) and Pipe Thermometer (right) during a free-burning pool fire test (Test 1.3).

It was found difficult to draw any conclusions of the efficiency of the water spray system if the absolute values of the average temperatures for different tests were used. The relative reduction of the average temperatures for different number of points is a more comparable indicator than using absolute values of the average temperatures. Thus, the tests using the water spray system were compared with corresponding free-burn test using different number of points included in the averaging, both close to the fire and close to the water spray system. A relative reduction means the average values obtained between 2 minutes and 12 minutes into the test, or in some few cases until the extinguishment time, divided by the corresponding values obtained from the free-burning test.

In Figure 8, a comparison is shown of the effects of different water densities on the reduction in the heat release rate for a 1 MW pool fires tests. The relative reduction of the HRR on the ordinate is the ratio of the average  $HRR_{tot}$  value obtained between 2 minutes and 12 minutes for 5 mm/min and 7,5 mm/min, respectively, and the corresponding  $HRR_{tot}$  for the same time period.

Figure 8 show clearly the effects of the system on the  $HRR_{tot}$ . It should be noted that the effect of the water discharge is very fast. The different levels of the  $HRR_{tot}$  are established within a short period of time.

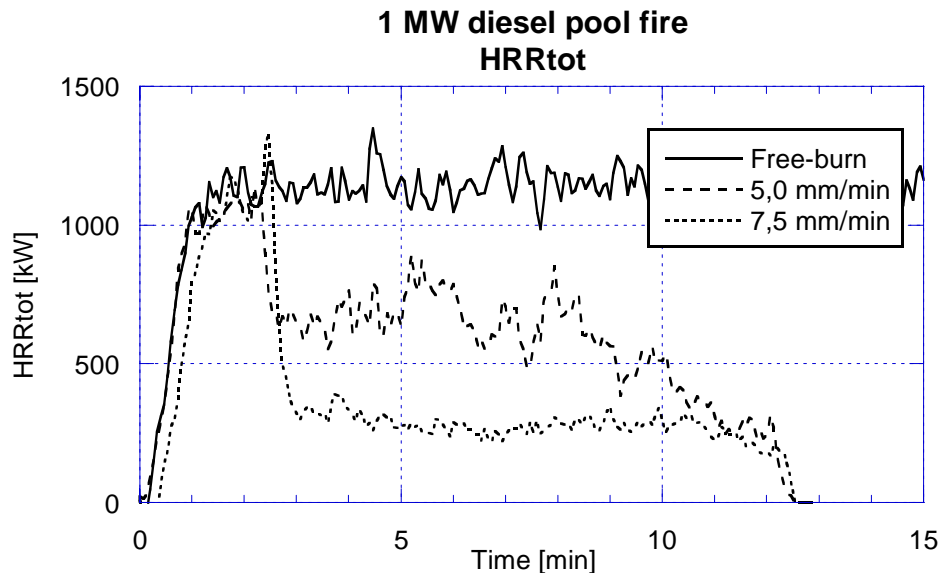

Figure 8 The measured  $HRR_{tot}$  for a free-burn test (Test 1.3FB(1)P) and for two different water densities 5 mm/min (Test 1.4WS(1)P) and 7,5 mm/min (Test 1.5WS(1)P).

The use of relative reduction of the measured surface temperature data of the Pipe Thermometer shows that the data representing 1, 3 or 5 points were very close to each other. In some cases they coincided with each other. The average standard deviation was found to be 0,046. For the Pipe Thermometer close to the fire, the use of 5 points tended to give the greatest relative reduction and one point the lowest relative reduction. For the Pipe Thermometer close to the water spray system (actually located above the system) the ranking become vice versa. The most probable cause for this is the cooling effects of the water spray droplets on the outer measurement points.

In the following analysis of the Pipe Thermometer data, the average value of 1, 3 and 5 points will be used. Due to the small variation in the results between 1, 3 or 5 points, the use of an average value of all data points gives a good representation of the data at both elevations.

In the following, a presentation of the measured data of the Pipe Thermometer surface temperature, gas temperature, radiation and Plate Thermometer temperatures are given separately.

## 7.2 Pipe Thermometers

In Figure 9, a plot of the average relative reduction of the surface temperature as a function of the relative reduction of the  $HRR_{tot}$  (left) and  $HRR_{conv}$  (right) is given for two elevations; close to the fire (CTF) and close to water spray system (WSS). A solid line representing equal values for both axes is shown as well. Low values of relative numbers indicate that the system is very effective,

whereas values close to unity indicates very little effect on the fire.

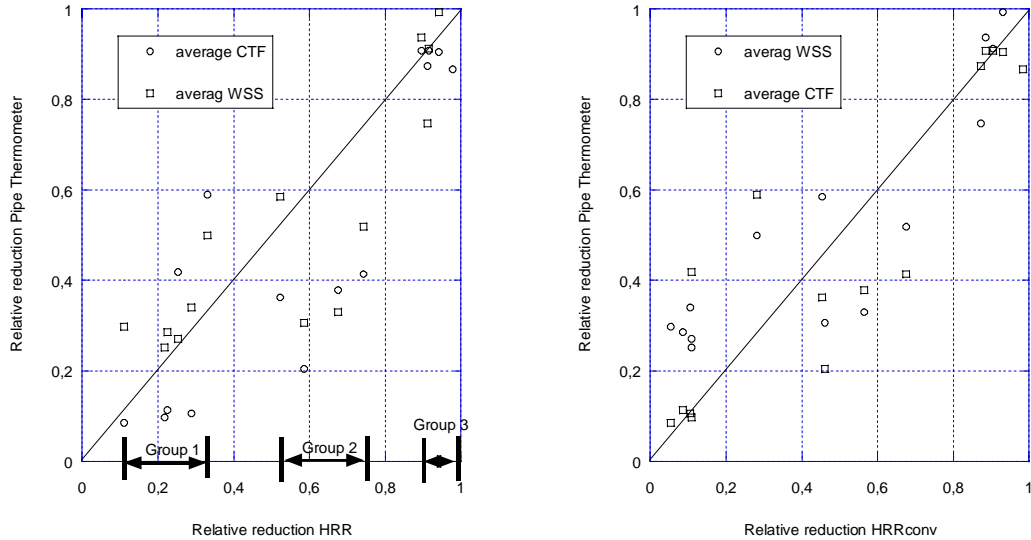

Figure 9 The relative reduction in average surface temperature (1, 3 and 5 points) of the Pipe Thermometer versus the relative reduction in the measured  $HRR_{tot}$  (left) and relative reduction in the  $HRR_{conv}$  (right) for all the performed tests. The line represents equal values for both axis.

With two exceptions, the relative reduction of the HRR was lower than 0,33 (0,28 for the convective HRR) in tests with water flow rate of 270 L/min. These were tests 2.5 and 2.9, which were spray tests with 2 MWs and 3,5 MWs, respectively. In all cases when the water flow rate was 180 L/min the relative reduction of the HRR was over 0,52 (0,45 for the convective HRR). When looking at the data it is possible to identify three groups of data sets in Figure 9.

- Group 1, the fire suppression group, with relative reduction of HRR less than 0,33,
- Group 2, the fire control group with relative reduction of the HRR between 0,52 and 0,74,
- Group 3, a group where nearly no effects were seen on the relative reduction of HRR. This data is represented by values of relative HRR reduction above 0,9, and where the data points herein from spray fire tests.

A linear curve fit of the data shows a better correspondence in the data for  $HRR_{conv}$  compared to  $HRR_{tot}$ . The linear correlation coefficient  $R$  is equal to 0,86 for  $HRR_{tot}$  and 0,89 for  $HRR_{conv}$ . An interesting observation is that nearly all the data points belonging to Group 2 are lower than the line of equality and in Group 1 the majority of the data points are above the line. The scatter in the data is considerable and it does not show any clear tendency to follow the line of equality, which is what would be expected if the hypothesis presented in introduction of chapter 7 were true. There is no obvious explanation available for this behaviour here. This is probably due to a complex phenomenon related to the rate of vaporisation of the water droplets on the Pipe Thermometer, which evidently will affect the reliability of the method.

### 7.3 Gas temperatures

In Figure 10, a plot of the average relative reduction of the gas temperature as a function of the relative reduction in the heat release rate (left) and convective heat release rate (right) is given for

two elevations, close to the fire (CTF) and close to water spray system (WSS). A solid line representing equal values for both axes is shown as well.

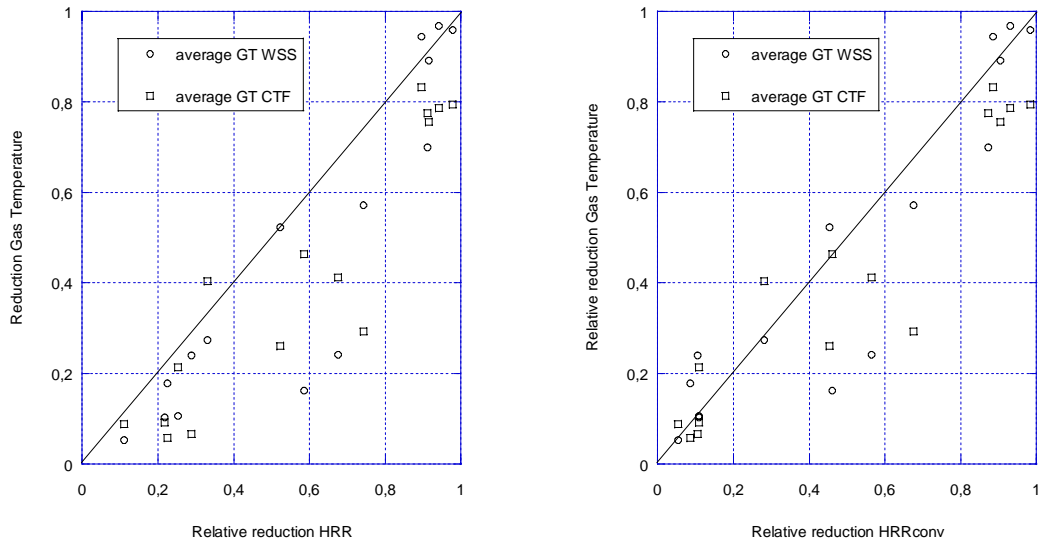

*Figure 10 The relative reduction in average gas temperature versus the relative reduction in the measured  $HRR_{tot}$  (left) and  $HRR_{conv}$  (right) for all the performed tests. The line represents equal values for both axis.*

The correspondence in the data is more in line with the hypothesis given previously. This data follows the line of equality more clearly than that obtained with the Pipe Thermometer, but there is still high scattering in the data. Further, a linear curve fit indicates a better correspondence in the data. For the  $HRR_{tot}$  the linear regression coefficient R is 0,91 and 0,93 for  $HRR_{conv}$ . As in Figure 9, there are three groups of data identified and there is a tendency that Group 2 is influenced by the water droplets.

It is clear from the analysis of the experimental data that using only thermocouples in the test method yields results which are slightly better than the data from the Pipe Thermometer.

## 7.4 Heat radiation measurements

In Figure 11, a plot of the average relative reduction of the heat radiation measurements as a function of the relative reduction in the heat release rate is given for two distances: 2 m and 4 m, respectively. A solid line representing equal values for both axes is shown as well.

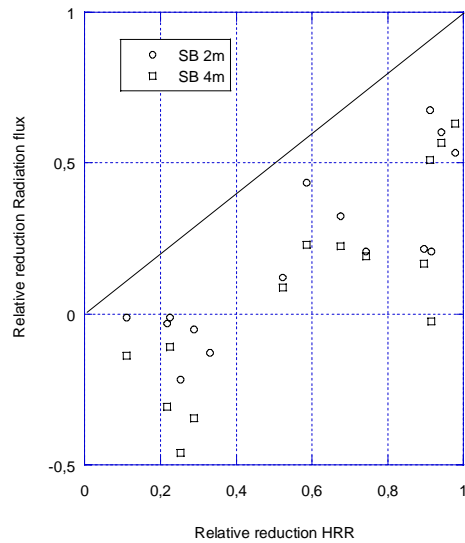

Figure 11 Relative reduction of the radiation as a function of the relative reduction of the  $HRR_{tot}$  at 2 m and 4 m. The line represents equal values for both axis.

The method of using heat flux gauges in order to measure the efficiency of the water spray system is a common procedure among fire test laboratories. As can be observed in Figure 11, there is an offset of the data compared to the Pipe Thermometer and the gas temperature measurements, which may be explained by absorption of radiation by the water spray or, alternatively, that the water droplets hit the sensors. All the data points belonging to the Group 1 indicates that they have been influenced by the water cooling on the sensors. The scatter in the data is higher compared to the Pipe Thermometer and the gas temperature. The linear regression coefficient  $R$  equals to 0,77 compared to 0,89 for the Pipe Thermometer and 0,91 for the gas temperature.

## 7.5 Plate Thermometers

In Figure 12, a plot of the average relative reduction of the Plate Thermometer as a function of the relative reduction in the heat release rate is given for two distances: 2 m and 4 m, respectively. A solid line representing equal values for both axis is shown as well.

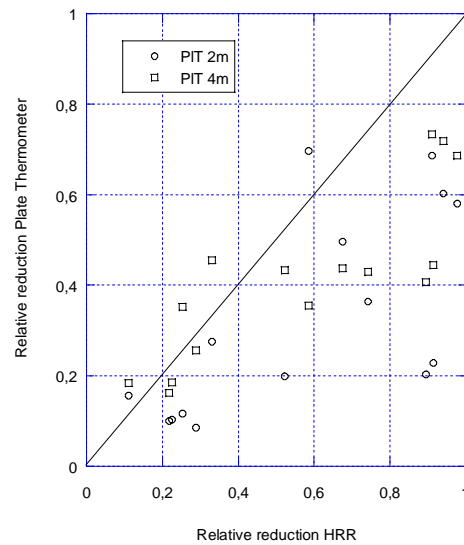

Figure 12 Relative reduction of the Plate Thermometer as a function of the relative reduction of the  $HRR_{tot}$  at 2 m and 4 m. The line represents equal values for both axis.

The method of using Plate Thermometers in order to measure the efficiency of the water spray system is simple and robust. There is, however, some offset of the data especially for Group 3 (spray fire tests). The influence of water droplets on attenuation of radiation is apparent in this case. The data scatter is higher compared to the Pipe Thermometer and the gas temperature measurements. The linear regression coefficient  $R$  equals to 0,72 compared to 0,77 for heat flux gauges, 0,89 for the Pipe Thermometer and 0,91 for the gas temperature.

## 8 Discussion of the test results

### 8.1 General

The Pipe Thermometers demonstrates that there is a weak correspondence between the effects of the water spray system on the fire size of the measured heat released. The Pipe Thermometer yields better correspondence of data ( $R=0,89$ ) than heat flux meters ( $R=0,77$ ) and Plate Thermometer ( $R=0,72$ ) which were located at a distance from the fire source. The best correspondence between the measured data below the water spray system and the measured heat release rate was found between the measured gas temperature data and the measured convective heat release data ( $R=0,93$ ).

The tests show that the effect of water droplet interaction with the instruments is an important parameter to consider when designing the test set-up and the instrumentation. Under certain conditions this influences the outcome of the tests, even when using thermocouples. Protections of the instruments against a direct hit from water droplets is, therefore, very important. It is maybe possible to improve the design of the Pipe Thermometer with a shield above its top surface, in order to prevent cooling by direct impact of water droplets.

In the following a discussion of the test results is given for both the diesel pool fire tests and the diesel spray fire tests.

### 8.2 Diesel pool fire tests

A summary of the relative reduction of the  $HRR_{tot}$  and  $HRR_{conv}$  is given in Table 16 for different nominal HRR and water discharge densities (mm/min). The relative reduction of  $HRR_{tot}$  and  $HRR_{conv}$  as a function of the nominal HRR has been plotted in Figure 13. As can be observed in Figure 13, all the tests using 7,5 mm/min discharge density (270 L/min), were more or less suppressed. All these tests belong to Group 1 defined in chapter 7.1, with relative reduction of the  $HRR_{tot}$  varying between 0,11 to 0,29. All the pool fire tests using 5 mm/min (180 L/min) were reduced and controlled by the water spray system. They all belong to Group 2 with relative reduction of  $HRR_{tot}$  between 0,52 to 0,74. No pool fire tests were found in Group 3 because the water density used in the tests suppressed or controlled all the pool fires.

The average  $HRR_{tot}$  and  $HRR_{conv}$  for the free-burn tests are shown in Table 16 for comparison. The 1 MW and 2 MW values are found to be quite close to the nominal values whereas the 3,5 MW and 6 MW show lower values. The main reason for this was a leakage of smoke from the hood system of the Industry Calorimeter. This will not influence the principal results of this study since all the data presented here are given in relative terms.

Table 16 The relative reduction of the Heat Release Rate for the diesel pool fires.

Nominal HRR <sub>tot</sub> [MW]	Average free-burn HRR <sub>tot</sub> [MW]	Average free-burn HRR <sub>conv</sub> [MW]	Water discharge density [mm/min]	Relative reduction, HRR <sub>tot</sub>	Relative reduction, HRR <sub>conv</sub>
1	1,15	0,72	5	0,523	0,454
2	2,06	1,11	5	0,742	0,676
3,5	3,14	1,90	5	0,675	0,565
6	5,12*	3,15*	5	0,586	0,46
1	1,15	0,72	7,5	0,289	0,105
2	2,06	1,11	7,5	0,225	0,086
3,5	3,14	1,90	7,5	0,217	0,108
6	5,12*	3,15*	7,5	0,111	0,054

\* There was some leakage of smoke outside the hood of the Industry Calorimeter observed during the test

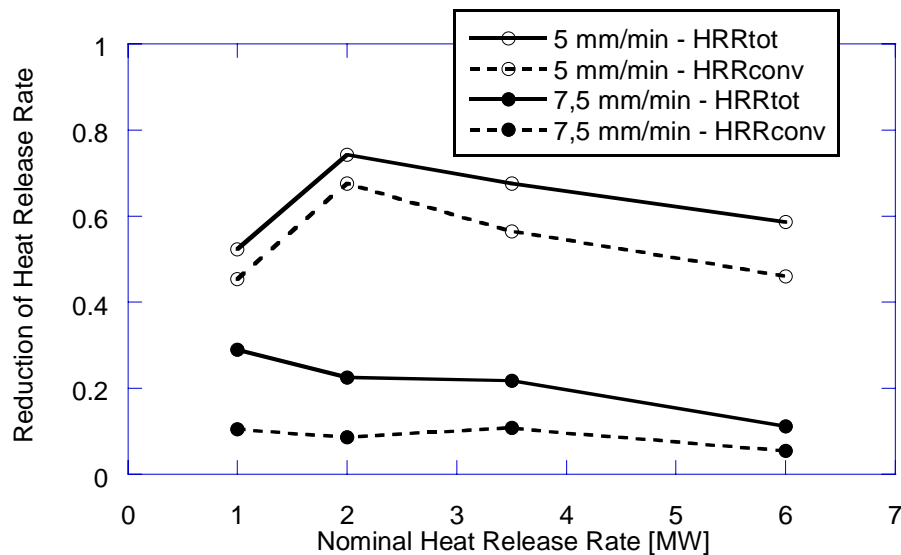

Figure 13 The relative reduction of the measured HRR as a function of the Nominal Heat Release Rate for different water densities.

An explanation to the relatively low value obtained with the 1 MW nominal HRR using the 5 mm/min discharge density has not been found. Similar values were obtained with the Pipe Thermometer and the gas temperatures. The general trend is that the relative reduction in the HRR tends to decrease as the nominal value increases.

### 8.3 Diesel spray fire tests

A summary of the relative reduction of the HRR<sub>tot</sub> and HRR<sub>conv</sub> is given in Table 17 for different nominal HRR and water discharge densities (mm/min). The relative reduction of HRR<sub>tot</sub> and HRR<sub>conv</sub> as a function of the nominal HRR has been plotted in Figure 14. All the spray fire tests, except for two tests using 7,5 mm/min, did not notably influence the fire size. These spray fire tests fit in to Group 3 defined in 7.1 except for a test with 7,5 mm/min and 1 MW fire, which fitted into Group 1. For larger fires and same density they were found in Group 3.

The average  $HRR_{tot}$  and  $HRR_{conv}$  for the free-burn tests are shown in Table 10 for comparison. The measured HRR is generally slightly higher than the nominal values. The main reason is that the combustion efficiency used prior to the tests (0,91) turned out to be higher than the one used in the design of the test. The results indicate a relatively complete combustion of the diesel during the tests.

Table 17 The relative reduction of the Heat Release Rate for the diesel spray fires.

Nominal HRR [MW]	Average free-burn $HRR_{tot}$ [MW]	Average free-burn $HRR_{conv}$ [MW]	Water discharge density [mm/min]	Relative reduction, $HRR_{tot}$	Relative reduction, $HRR_{conv}$
1	1,12	0,67	5	0,911	0,872
2	2,28	1,42	5	0,941	0,93
3,5	3,78	2,31	5	0,979	0,983
1	1,12	0,67	7,5	0,33	0,282
2	2,28	1,42	7,5	0,915	0,904
3,5	3,78	2,31	7,5	0,895	0,885

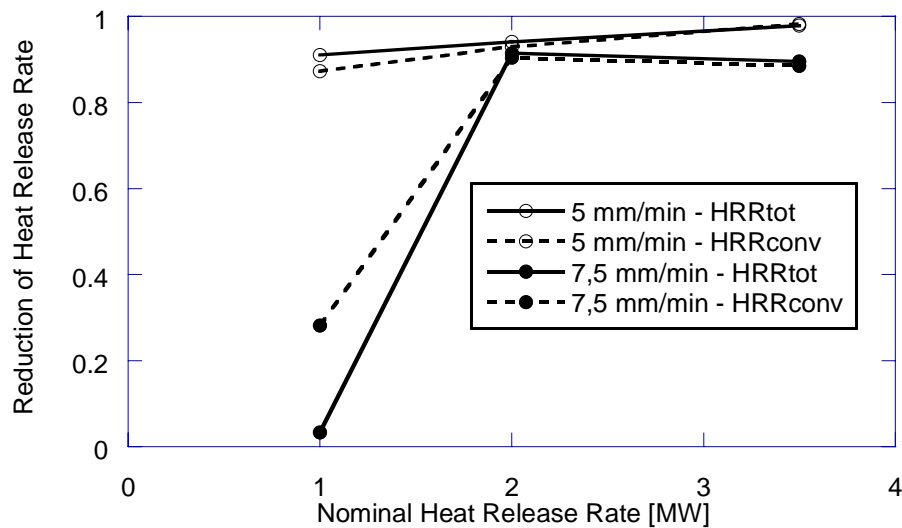

Figure 14 The relative reduction of the measured HRR as a function of the Nominal Heat Release Rate for different water densities.

A very distinct threshold to obtain fire suppression for spray fires is observed in Figure 14. The data show that the effects of the water on the reduction of the HRR is very low, except in one test with 7,5 mm/min and low nominal HRR.

## 9 Conclusions

The objective was to develop a test methodology that makes it possible to measure and quantify the effectiveness of water spray or water mist systems for 'large' shipboard machinery spaces.

Heat Release Rate calorimetry is usually the best alternative for such evaluation. Not all fire laboratories have access to such equipment so other alternatives were investigated. A methodology that is based on as simple and robust measurement techniques as possible without using Heat Release Rate calorimetry was therefore explored.

The efficiency of the water spray system was evaluated by comparing the data from the free-burning tests to the data from the corresponding fire suppression test. A hypothesis saying that the relative reduction, compared to corresponding free-burning test, in the average values of different instruments located in the vicinity of the fire correlates to the corresponding relative reduction in the average heat release rate and/or the convective heat release rate, was investigated.

The study shows that the Pipe Thermometer is a better method than using heat flux meters or Plate Thermometer which were located at a distance from the fire source. The best correspondence between the measured data below the water spray system and the measured heat release rate was found between the measured gas temperature data and the measured convective heat release data. Consequently, there is no clear advantage of using the Pipe Thermometer (as mounted here) compared to traditional thermocouples at similar locations.

It should be noted that the use of thermocouples has been applied previously by others. For example, an evaluation of the effectiveness of different sprinkler and water spray nozzles against liquid pool fires using gas temperature measurements above the fuel has been presented in [9]. These tests lacked the reference measurements using heat release rate calorimetry, but used different fuels and different water spray nozzles.

## References

- 1 Arvidson, Magnus and Hertzberg, Tommy, "The VINNOVA water mist research project: A description of the 500 m<sup>3</sup> machinery space tests", SP Report 2003:19, SP Swedish National Testing and Research Institute, Borås, 2003
- 2 Arvidson, Magnus and Hertzberg, Tommy, "The VINNOVA water mist research project: A description of the 250 m<sup>3</sup> machinery space tests", SP Report 2003:29, SP Swedish National Testing and Research Institute, Borås, 2003
- 3 Arvidson, Magnus and Hertzberg, Tommy, "The VINNOVA water mist research project: An overview of the tests and test results", Proceedings from the 3<sup>rd</sup> International Water Mist Conference, Madrid, September 22 – 23, 2003
- 4 Hertzberg, Tommy and Arvidson, Magnus, "The VINNOVA water mist research project: A detailed analysis of the test results", Proceedings from the 3<sup>rd</sup> International Water Mist Conference, Madrid, September 22 – 23, 2003
- 5 Arvidson, Magnus and Hertzberg, Tommy, "A new methodology to evaluate the performance of total compartment water mist and water spray systems", Tenth International Interflam 2004 Conference, 2004
- 6 Wickström, Ulf, "The plate thermometer - A simple instrument for reaching harmonized fire resistance tests", SP-REPORT 1989:03, Swedish National Testing and Research Institute, Borås, 1989
- 7 Wickström, Ulf, "The plate thermometer - A simple instrument for reaching harmonized fire resistance tests", Fire Technology, Volume 30, No. 2, 1994
- 8 International Code for Fire Safety Systems (FSS Code), Resolution MSC.98(73), International Maritime Organization, London, UK, 2001
- 9 Kokkala, Matti, "Extinguishment of liquid pool fires with sprinklers and water sprays, analysis of the test results", Technical Research Centre of Finland, Fire Technology Laboratory, VTT Research Reports, version 1990-07-31

## Appendix A - HRR measurement graphs

### Diesel pool fires

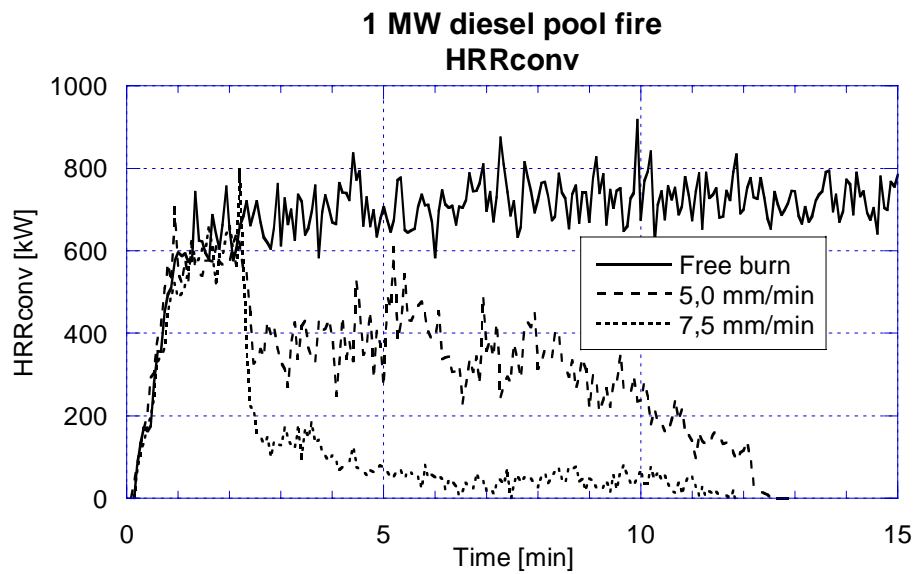
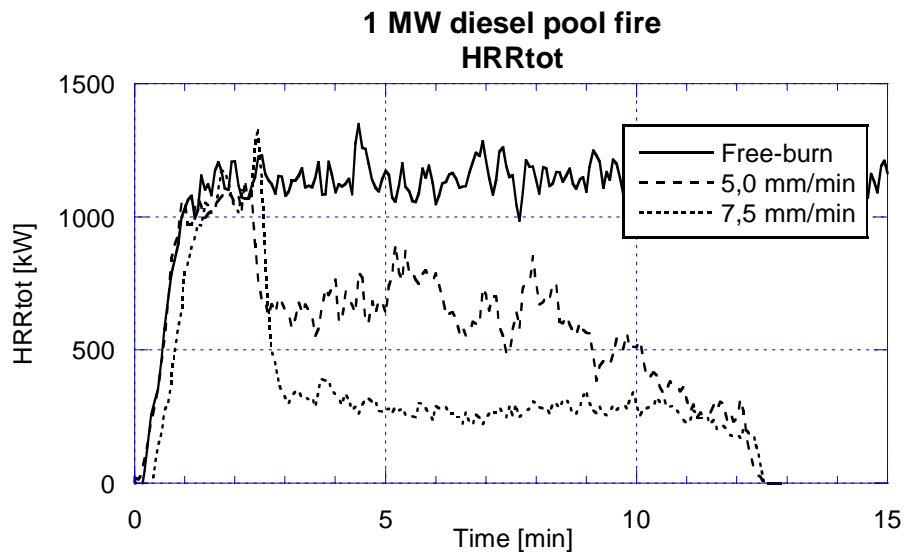

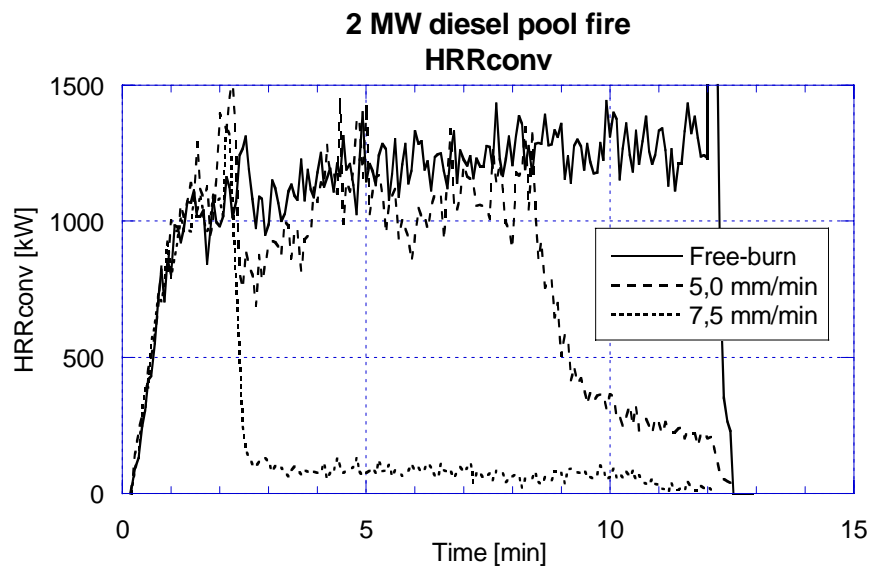
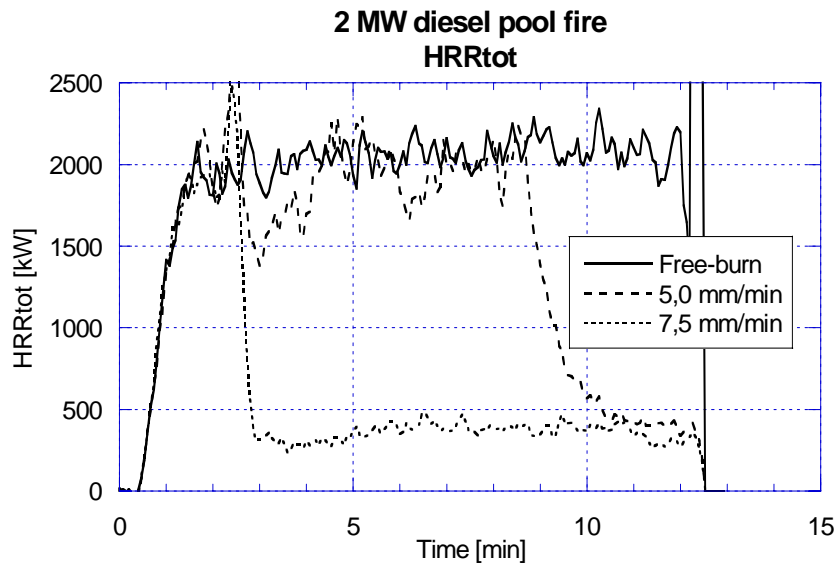

**3,5 MW diesel pool fire  
HRR<sub>tot</sub>**

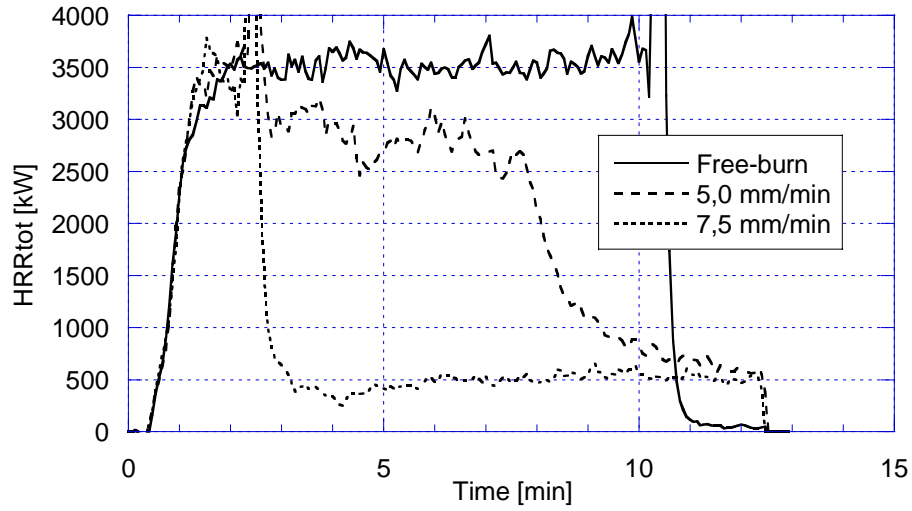

**3,5 MW diesel pool fire  
HRR<sub>conv</sub>**

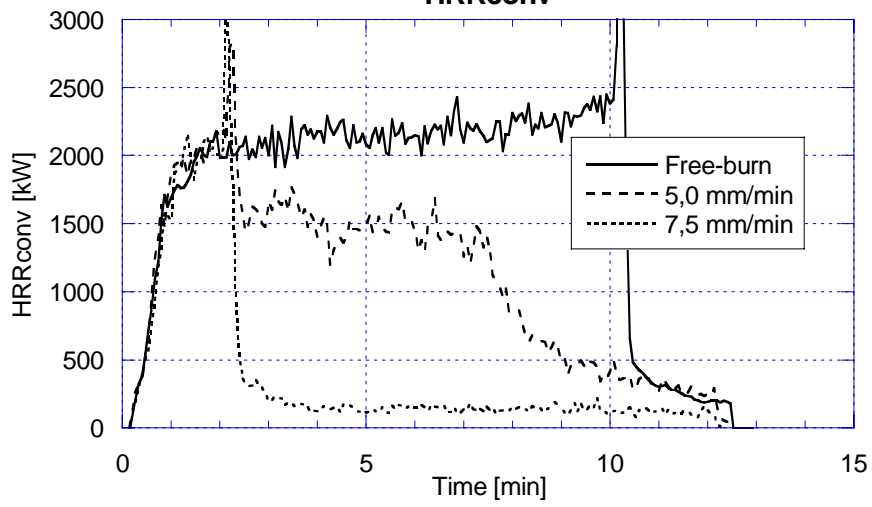

6 MW diesel pool fire  
HRRtot

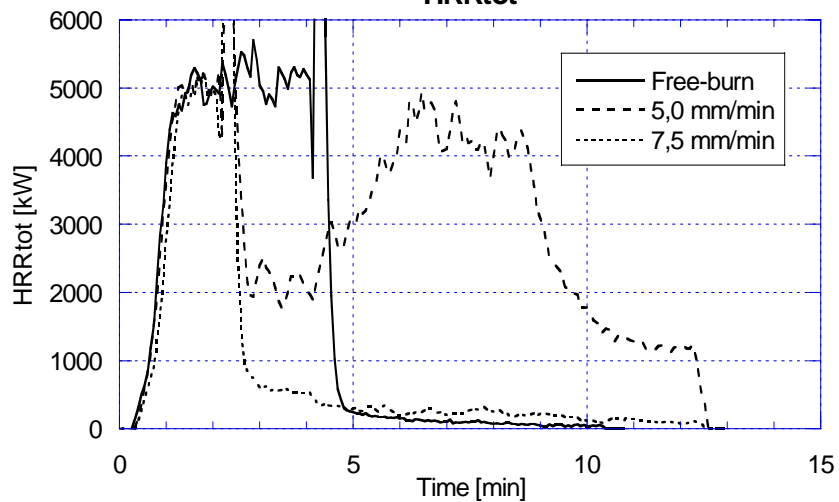

6 MW diesel pool fire  
HRRconv

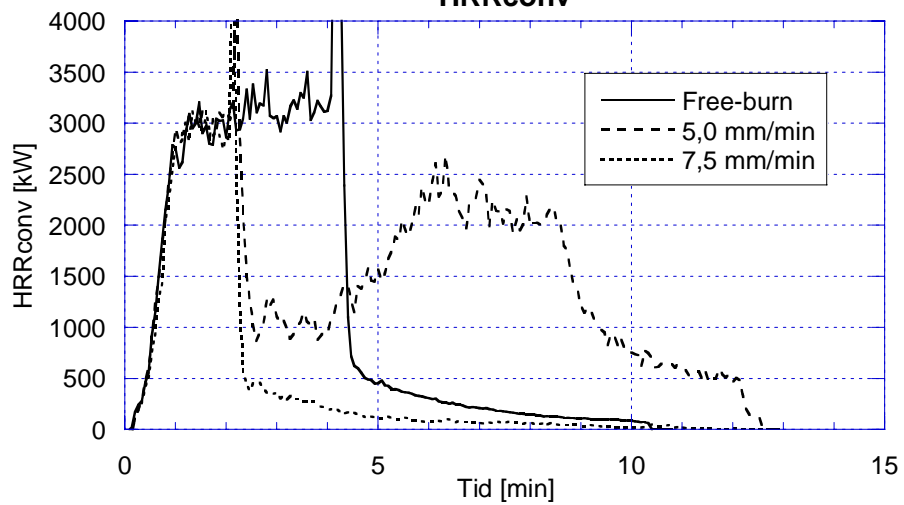

## Diesel spray fires

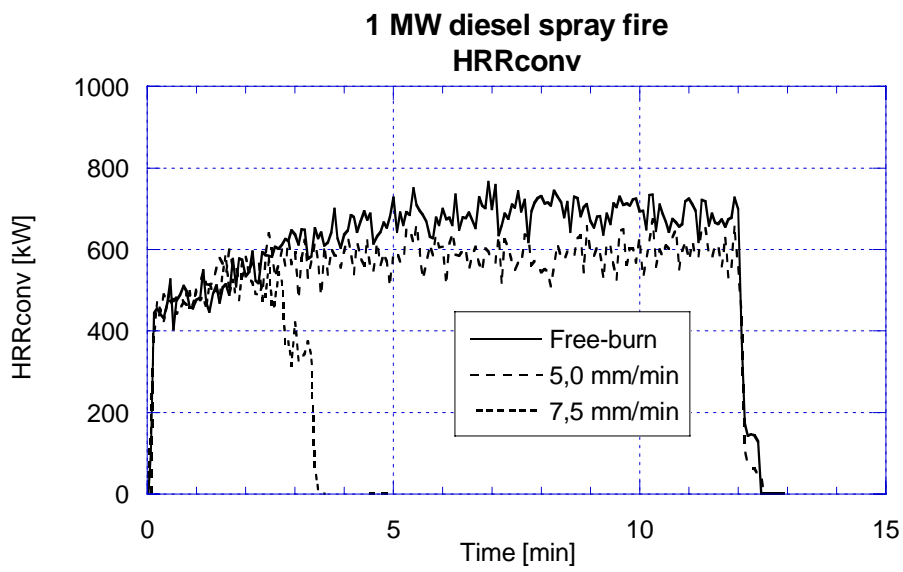
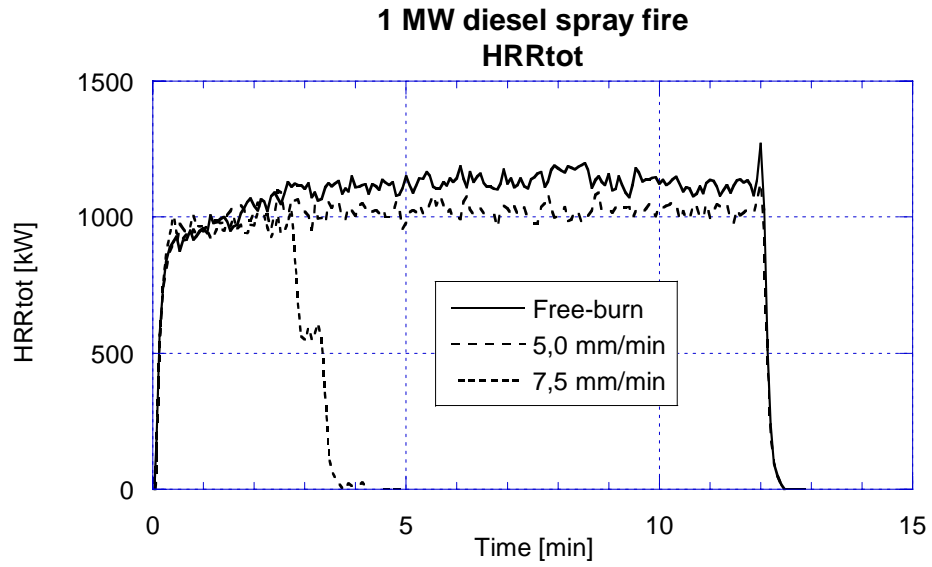

**2 MW diesel spray fire  
HRRtot**

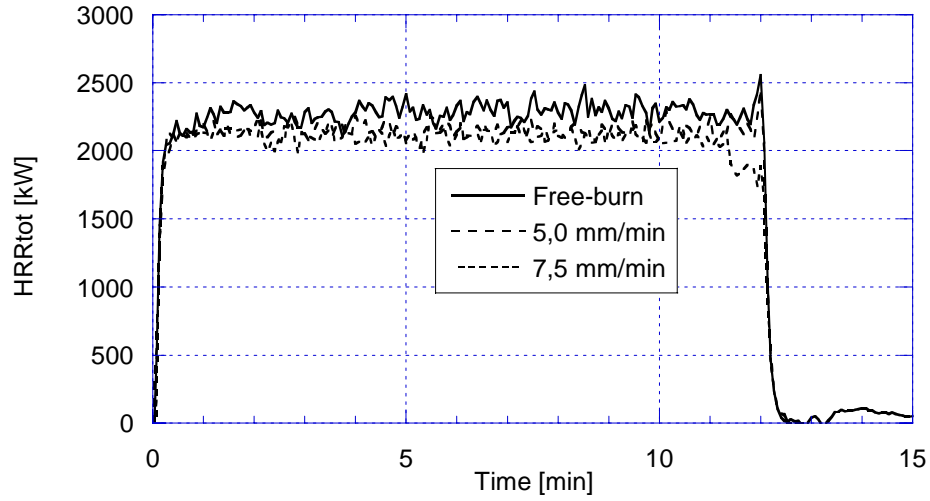

**2 MW diesel spray fire  
HRRconv**

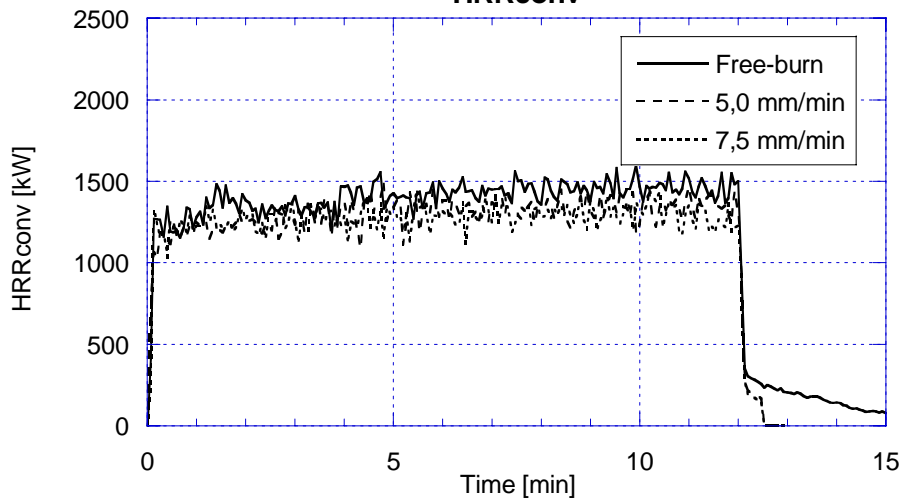

**3,5 MW diesel spray fire  
HRRtot**

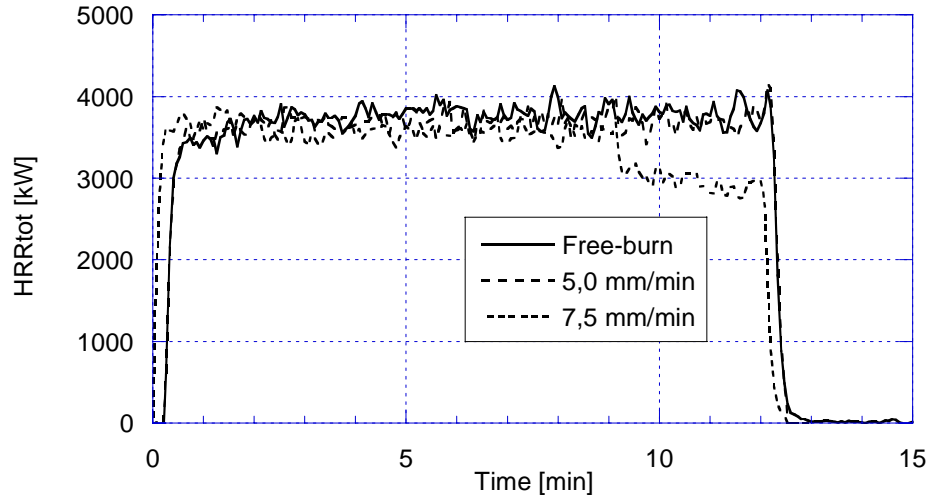

**3,5 MW diesel spray fire  
HRRconv**

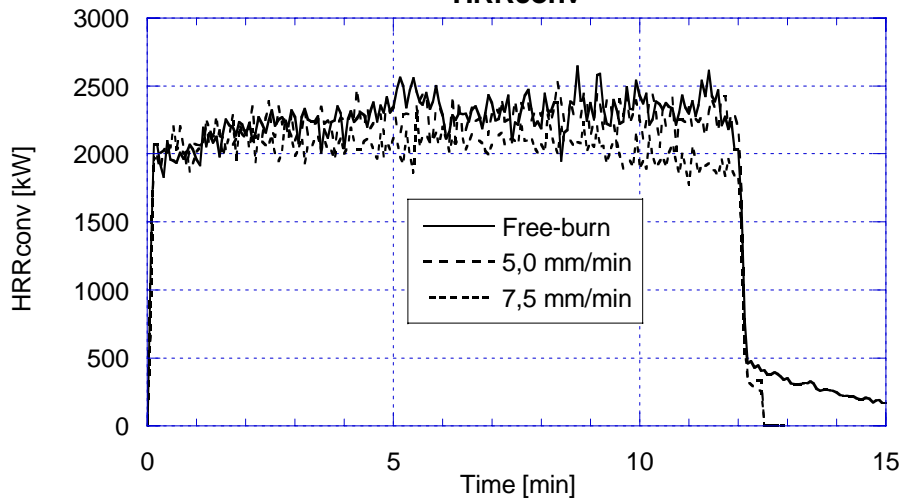

## Appendix B - Selected photos from the tests



*Photo 1 Free-burn of the 3,5 MW diesel pool fire.*



*Photo 2 Fire control of the 3,5 MW diesel pool fire using the water discharge density of 5,0 mm/min.*



*Photo 3 Fire suppression of the 3,5 MW diesel pool fire using the water discharge density of 7,5 mm/min.*



*Photo 4 The 3,5 MW diesel spray fire at the 5,0 mm/min water discharge density.*



*Photo 5 The 3,5 MW diesel spray fire at the 7,5 mm/min water discharge density.*

**SP Swedish National Testing and Research Institute** develops and transfers technology for improving competitiveness and quality in industry, and for safety, conservation of resources and good environment in society as a whole. With Swedens widest and most sophisticated range of equipment and expertise for technical investigation, measurement, testing and certification, we perform research and development in close liaison with universities, institutes of technology and international partners.

SP is a EU-notified body and accredited test laboratory. Our headquarters are in Borås, in the west part of Sweden.

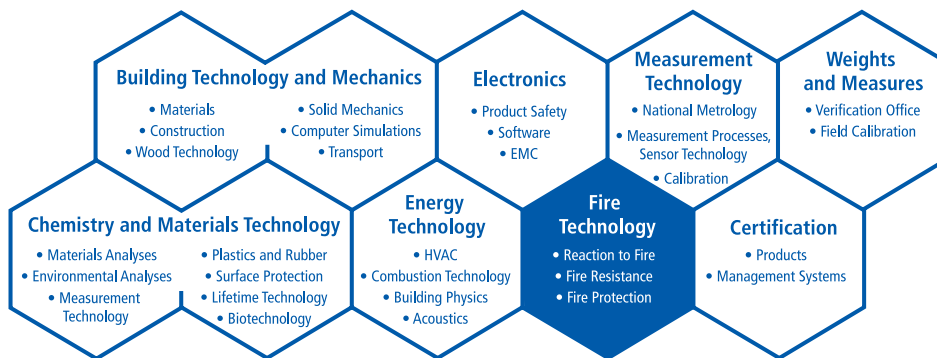

SP Fire Technology  
 SP REPORT 2005:33  
 ISBN 91-85303-64-X  
 ISSN 0284-5172



**SP Swedish National Testing and Research Institute**

Box 857  
 SE-501 15 BORÅS, SWEDEN  
 Telephone: + 46 33 16 50 00, Telefax: +46 33 13 55 02  
 E-mail: info@sp.se, Internet: www.sp.se

*A Member of*

